MPLS OAM: Standards and Solutions



Agenda

- Standards
 - Requirements First!
 - LSP Ping/Trace
 - LSR Self-Test
 - BFD
 - PWE3 VCCV
 - OAM Interworking
 - Ethernet OAM
- Where are the Gaps?

MPLS OAM Requirements

Highly Condensed Summary

- IETF draft-ietf-mpls-oam-requirements-04.txt
- ITU Recommendation Y.1710
- Management – a strong requirement for service delivery
 - Fault management
 - Service Management
- ILEC market has a very different view of network management when compared to ISPs
 - Fault detection, isolation
- suppress unnecessary alarms
- Customers View
 - Validation of control and data planes
- Flexible/automated detection and diagnosis of LSP status
 - PHP, ECMP
- Data plane OAM packets must follow same path as data.

LSP Ping

- Similar to ICMP (IP) Ping
 - Sequence Number
 - Timestamps
 - Sender Identification
- Full identification of FEC based the application
- Variable length for MTU discovery
- Support for tunnel/path tracing
- Multiple-reply modes
- Handles ECMP (a few problems to work out)
- Use to verify/trace PE-PE tunnel LSPs.
- <http://www.ietf.org/internet-drafts/draft-ietf-mpls-lsp-ping-06.txt>

LSR Self-Test Overview of Operation

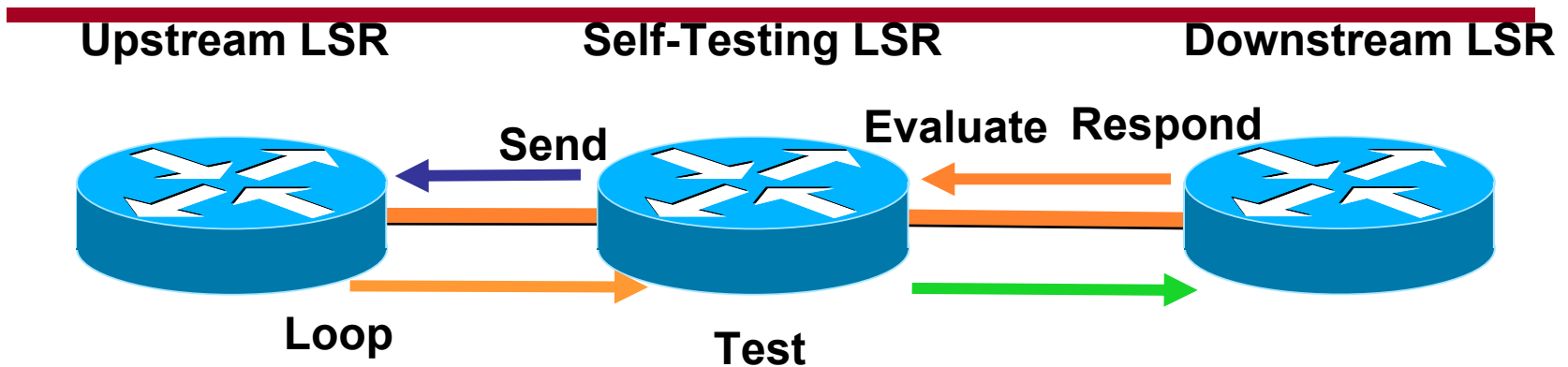

Two messages, five actions:

- Echo Request
 - Send (CP)
 - Loop (DP)
 - Test (DP)
- Echo Reply
 - Respond (CP*)
 - Evaluate (CP)

CP – Control Plane *Handled on linecard
DP – Data Plane

Bi-directional Forwarding Indication (BFD) Overview of Operation

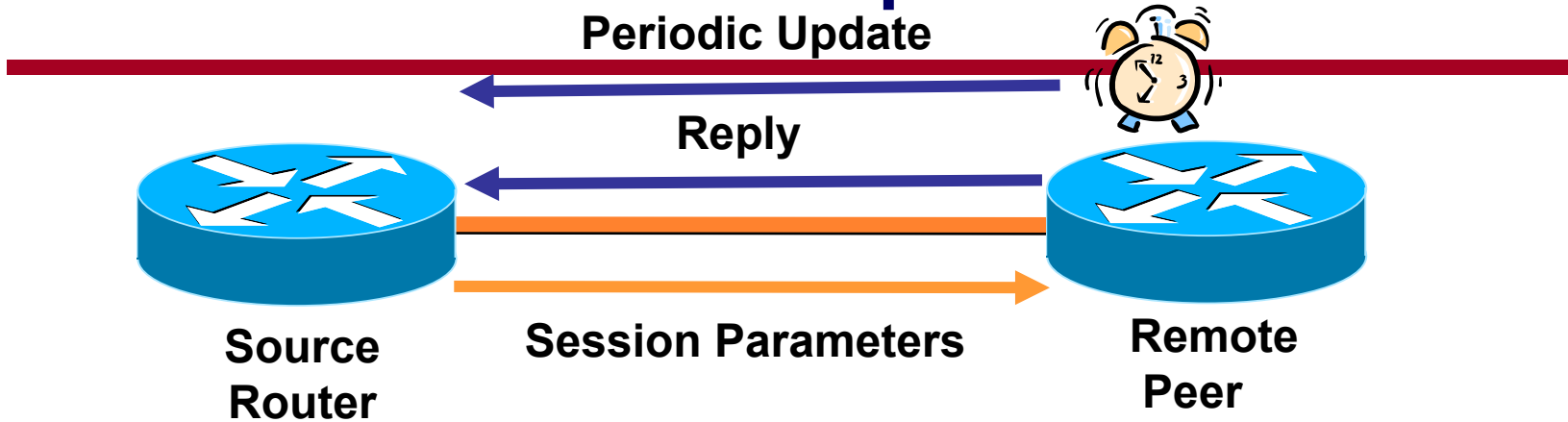

- Simple, fixed-field, hello protocol.
Easily implemented in hardware.
Very useful as a fault-detection mechanism.
- Nodes transmit BFD packets periodically over respective directions of a path
- If a node stops receiving BFD packets some component of the bidirectional path is assumed to have failed

Virtual Circuit Connection Verification (VCCV)

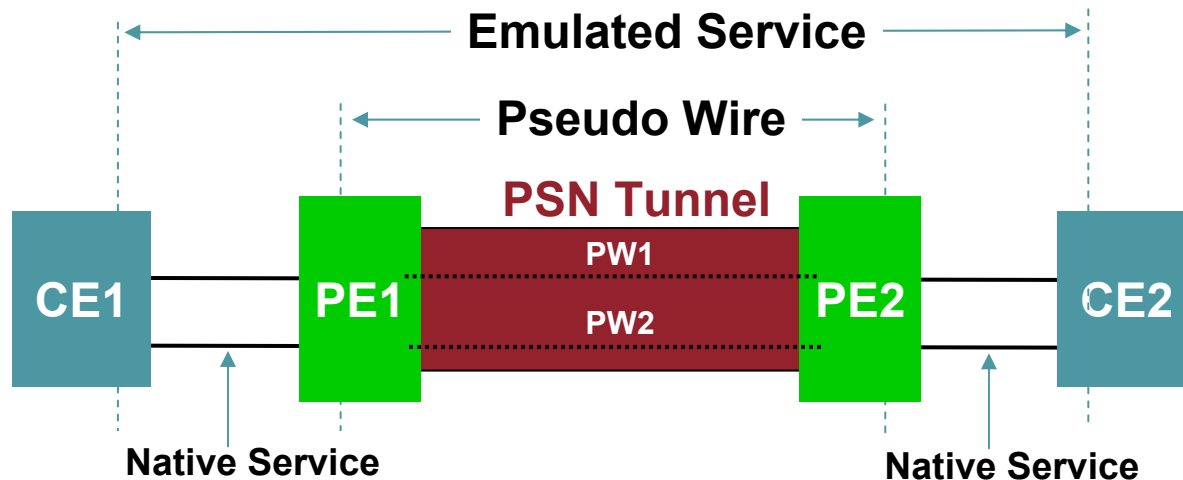

- <http://www.ietf.org/internet-drafts/draft-ietf-pwe3-vccv-04.txt>

Example of Operation CV/Trace Using VCCV and LSP Ping

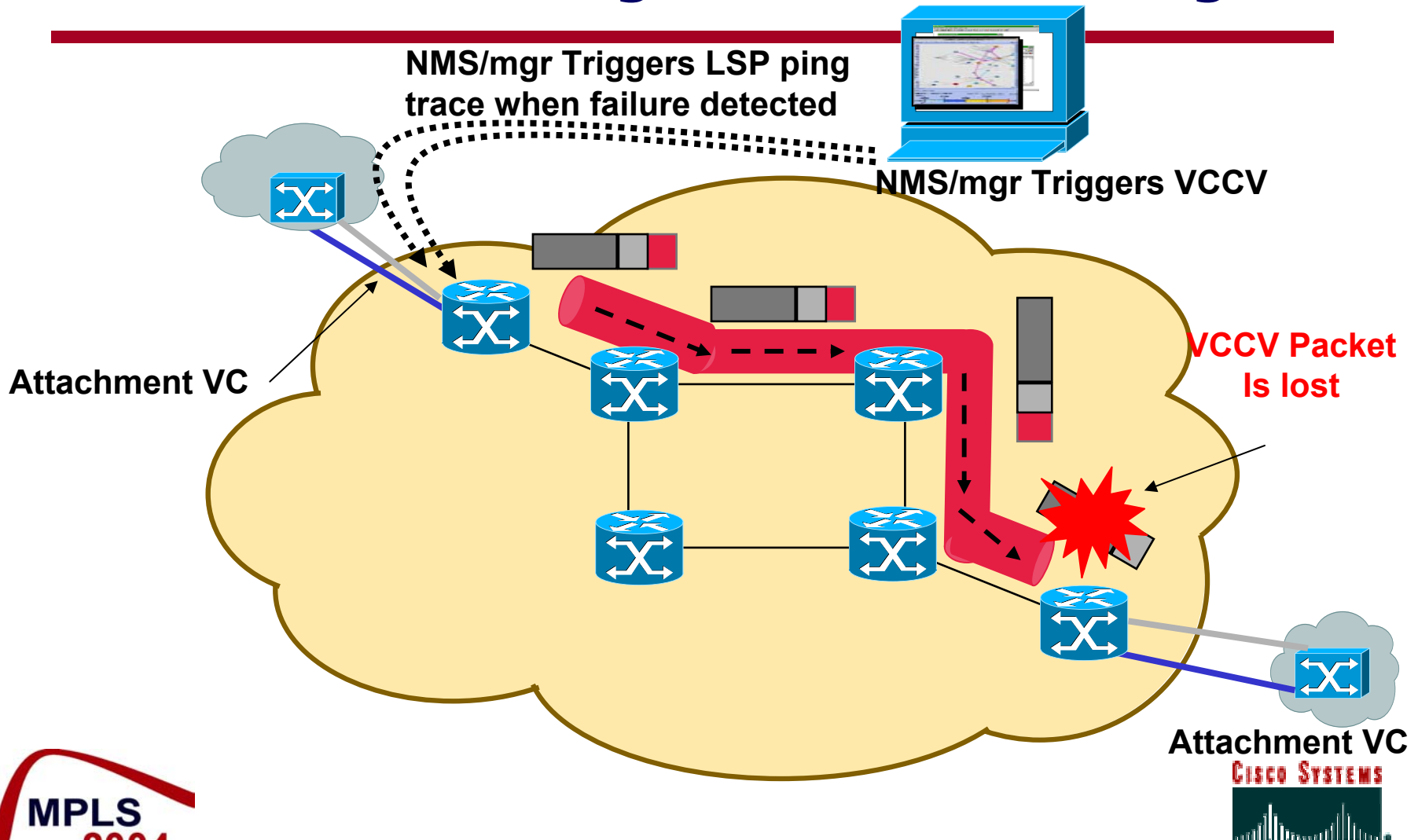

OAM Message Mapping Interworking

- Translate transport net defects into emulated circuit's native OAM.
- Documented in: draft-ietf-pwe3-oam-msg-map-00.txt

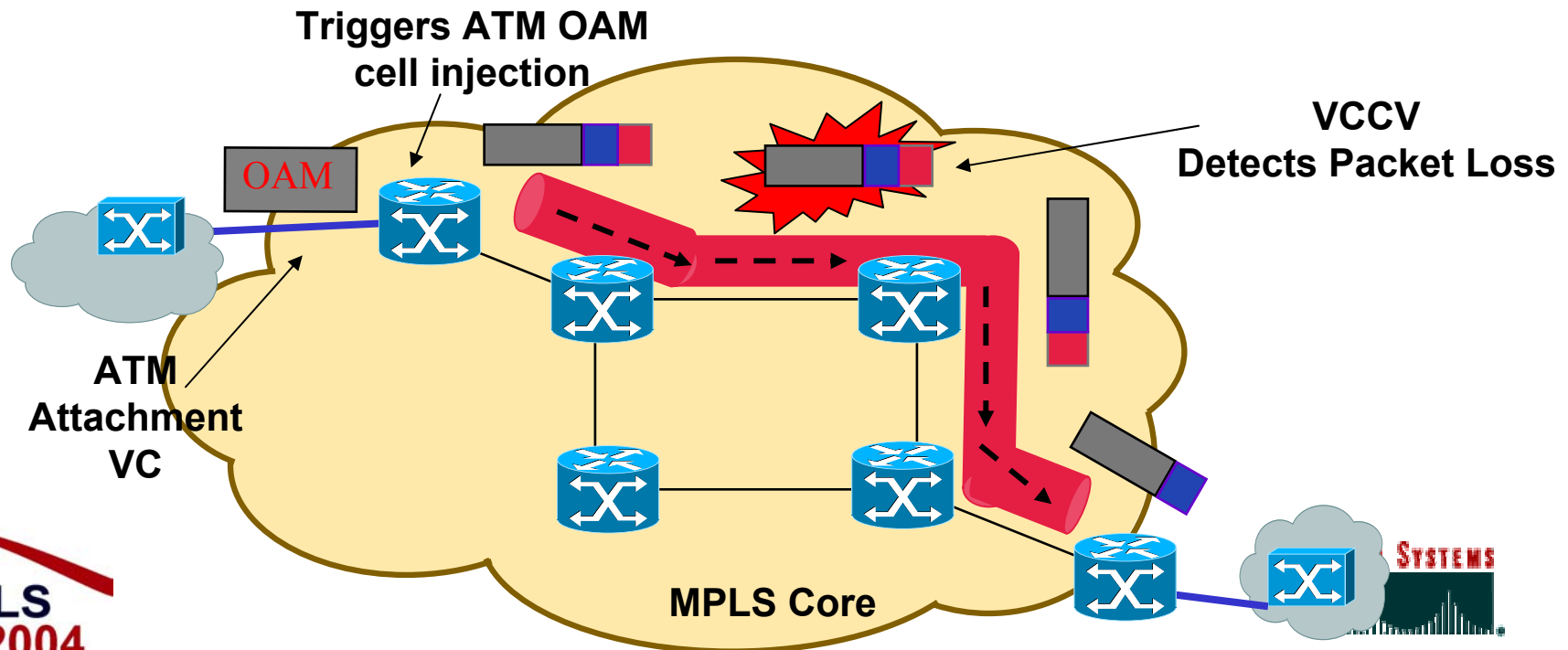

OAM Message Mapping Example

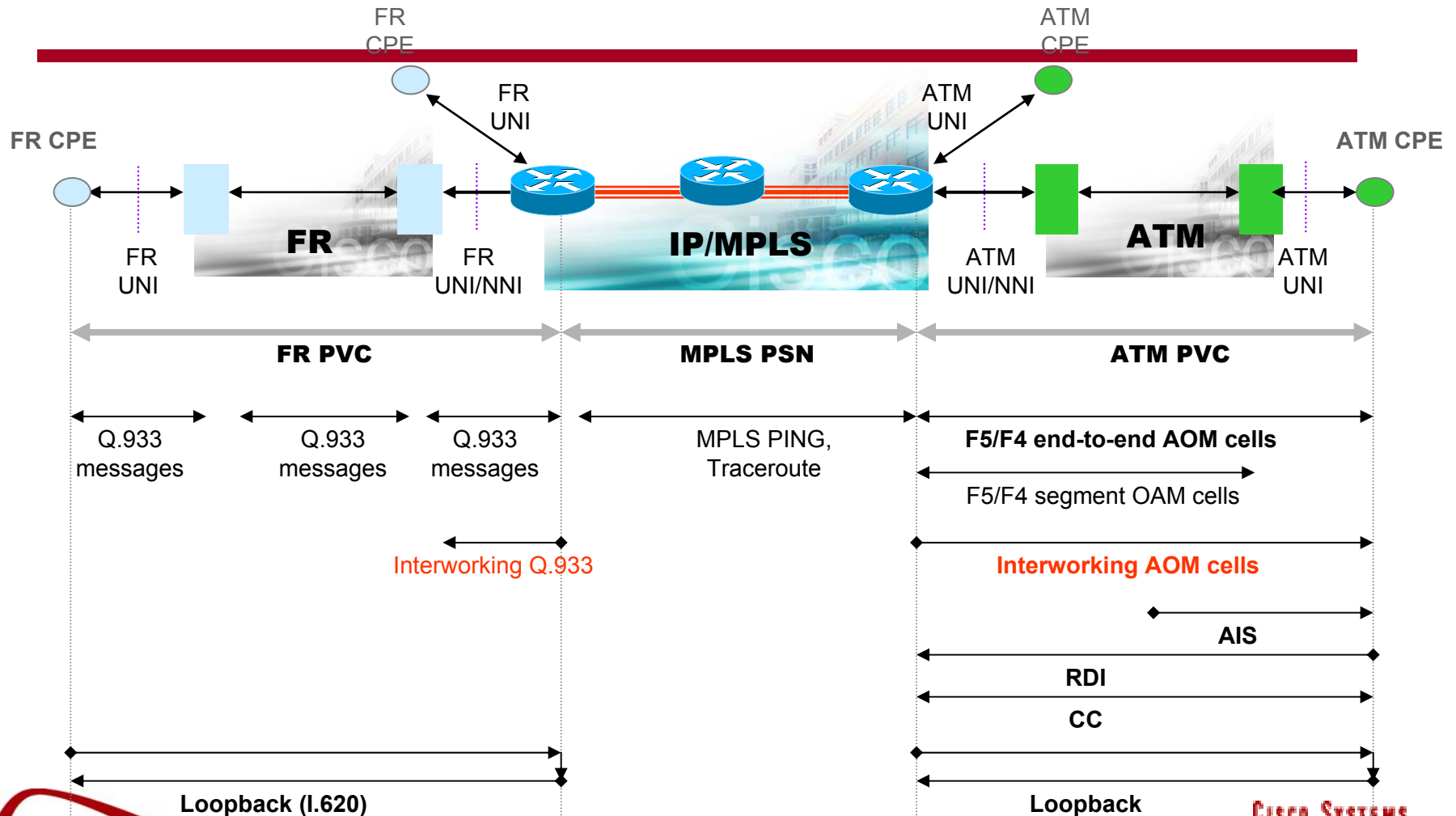

Ethernet OAM

A Layered Approach

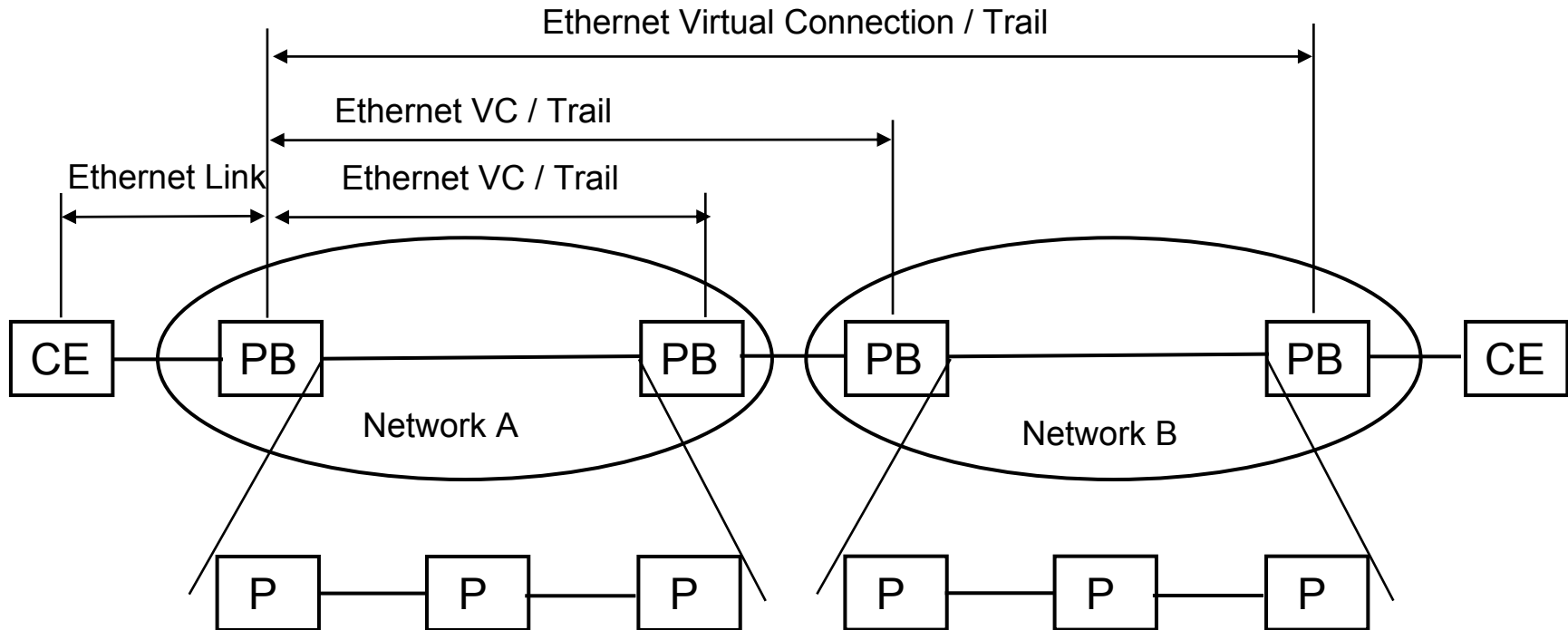

CEs: Customer Equipment

PBs: Provider Bridges serve as Ethernet connecting points (they can also terminate an Ethernet Trail)

Ps: Provider nodes serve as transport connecting point

Where Are the Gaps?

- GMPLS OAM
- VPLS OAM
- 3rd party tools and OSS integration

Thank You

